

A

B

C

D

No	Revizyon Tarihi (Revision Date)	Revizyon Açıklaması (Revision Description of Revision)	Revizyon Numarası (Revision Number)	Onay (Approval)
1				

ESKA

CE

0036

Pin=18-20 bar(g)
Pout=500 mbar(g)
Popso=820 mbar(g)
Pupso=250 mbar(g)
Prelief=720 mbar(g)
Qmax=160 SCMH
Serial No: #####
Week/Year: ##/## (W/Y)
Model ERG-H1

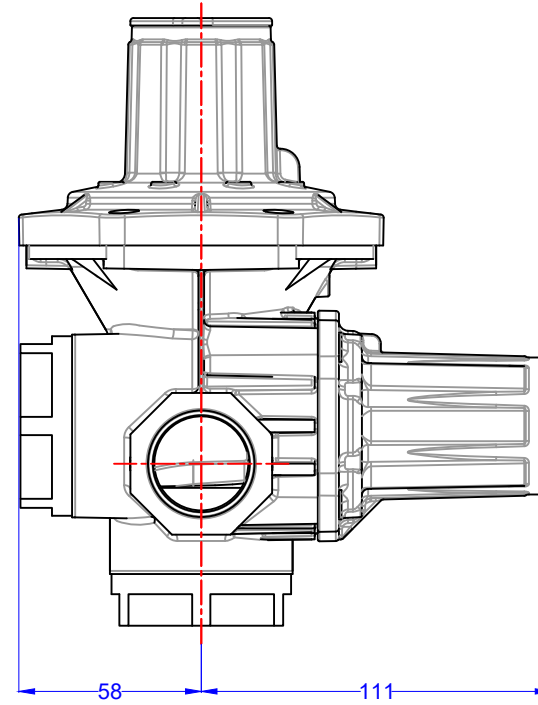
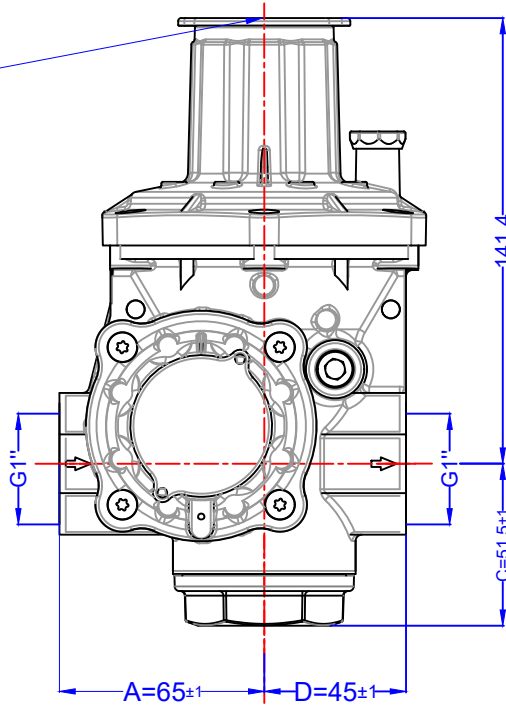

*Bezli Diyafram Kullanılacaktır.

Ürün Özellikleri / Product Spec.

Qmax=	160 SCMH
Pin=	18-20 bar(g)
Pout=	500 mbar(g)
Popso=	820 mbar(g)
Pupso=	250 mbar(g)
Prelief=	720 mbar(g)
A. Class=	AC10,SG30
Design Temperature=	-20 to 60°C

Ad - Soyad (Name And surname)		Tarih (Date)	İmza (Signature)	Referanslar (Preferences)	
Çizen (Drawn by)		Halil ÖZKAY	24-08-2021	-	
Kontrol (Checked by)		Samet ÖZDEMİR	24-08-2021	Parça Ağırlığı (Part Weight)	
Onaylayan (Approved by)				-	
Açısal Toleranslar (Angular Tolerances)		İşaretleme (Markings)			Malzeme Kalitesi (Material Quality)
0° - 10° ± 30'	10° - 50° ± 1°	Geçici (Temporary) =	Referans (Reference) ()	Temel (Basic) □	Fikstür (Fixture) < >
		Kontrol (Control) []			Yüzey İşlemi (Surface Treatment)
		Doğrusal Toleranslar (Linear Tolerances)			Resim / Parça Adı (Drawing / Part Name)
50° - 90° ± 1°30'	90° - 180° ± 2°	0,5 - 6 mm ± 0,1 mm	6 - 30 mm ± 0,2 mm	30 - 120mm ± 0,3 mm	120-400mm ± 0,4 mm
		400-1000mm ± 0,5 mm			Ölçek (Scale)
					Kağıt Boyutu (Page size)
					1/1
					A4
					Resim No (Drawing No) / Parça No (Part No)
					0047.01.002
					Sayfa No (Page No)
					1/1

ESKA

Açıklama (Explanation)

Gass Partner Norge

ERG-H1

0047.01.002

1/1

A

B

C

D