

Double Check Filler Valves for Delivery Truck Tanks and Large Storage Containers 7579S, 6587EC and 3197C

Application

Designed to provide fast filling of bobtails, transports and large bulk storage tanks.

The 6587EC incorporates a swing-away lower check which greatly reduces pressure drop across the valve. This lower pressure drop promotes faster filling rates and greater efficiency resulting in more profitable operations.

Features

- Double back check provides added system protection.
- Upper filler valve assembly can be easily replaced without evacuating the container.
- Both checks are spring actuated for quick, precise closure when flow into the valve stops or reverses.
- 6587EC swing-away check promotes up to 65% faster filling rates for more profitable operations. Faster filling rates add longer pump life by reducing chances of cavitation.
- Specify RegO Filler Valves on all your original tank purchases to ensure quality and dependable performance.

Materials

Upper Body.....	Brass
Lower Body (7579S and 6587EC).....	Brass
Lower Body (3197C).....	Plated Steel
Springs	Stainless Steel
Washer and Seat Discs	Synthetic Rubber
Cap (6587EC and 3197C).....	Brass
Cap (7579S).....	Plastic



7579S

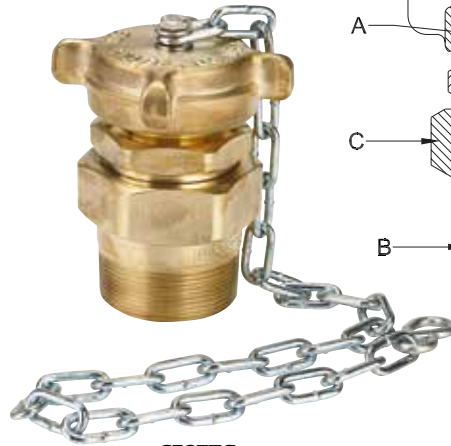
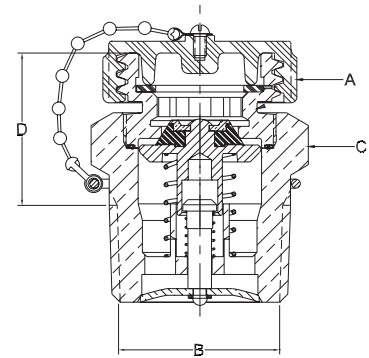

6587EC

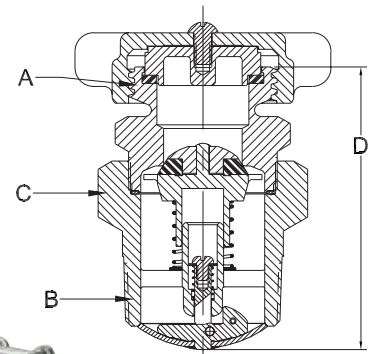

3197C

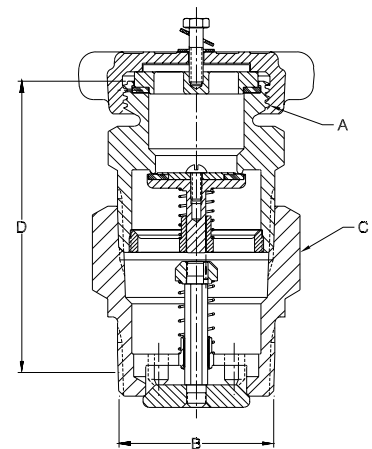

Ordering Information

Part Number	A. ACME Hose Connection	B. Tank Connection M. NPT	C. Wrench Hex Flats	D. Effective Length (Approx.)	Propane Liquid Capacity at Various Differential Pressures (GPM)				
					5 PSIG	10 PSIG	25 PSIG	50 PSIG	75 PSIG
7579S	1 3/4"	1 1/2"	2"	2 1/16"	44	62	98	139	170
6587EC*	2 1/4"	2"	2 7/8"	4 3/8"	92	130	206	291	356
3197C	3 1/4"	3"	4"	6 1/2"	148	210	332	470	575

* Swing-away lower back check valve design for higher filling rates.
NOTE: Multiply flow rate by .94 to determine liquid butane capacity.